

**CONFIDENTIAL NOTICE:** This drawing and the designs, specifications, and engineering information herein are the property of Eberhard Manufacturing Company and are not to be disseminated or reproduced without express written consent. This drawing is loaned in confidence and then only for the consideration of the matter disclosed herein. In accepting loan of this drawing, recipient agrees to keep it and the matter disclosed herein in confidence and not to use or permit their use in any way detrimental to Eberhard Manufacturing Company, Division of The Eastern Company, 21944 Drake Road, Cleveland, Ohio, 44149-9712 © 2021 EBERHARD MFG. CO.

REVISION HISTORY					
REV	DESCRIPTION	EN	DATE	REV. BY	APVD. BY
-	RELEASED WAS 10-M13185	6062	7/29/2022	VRB	MR

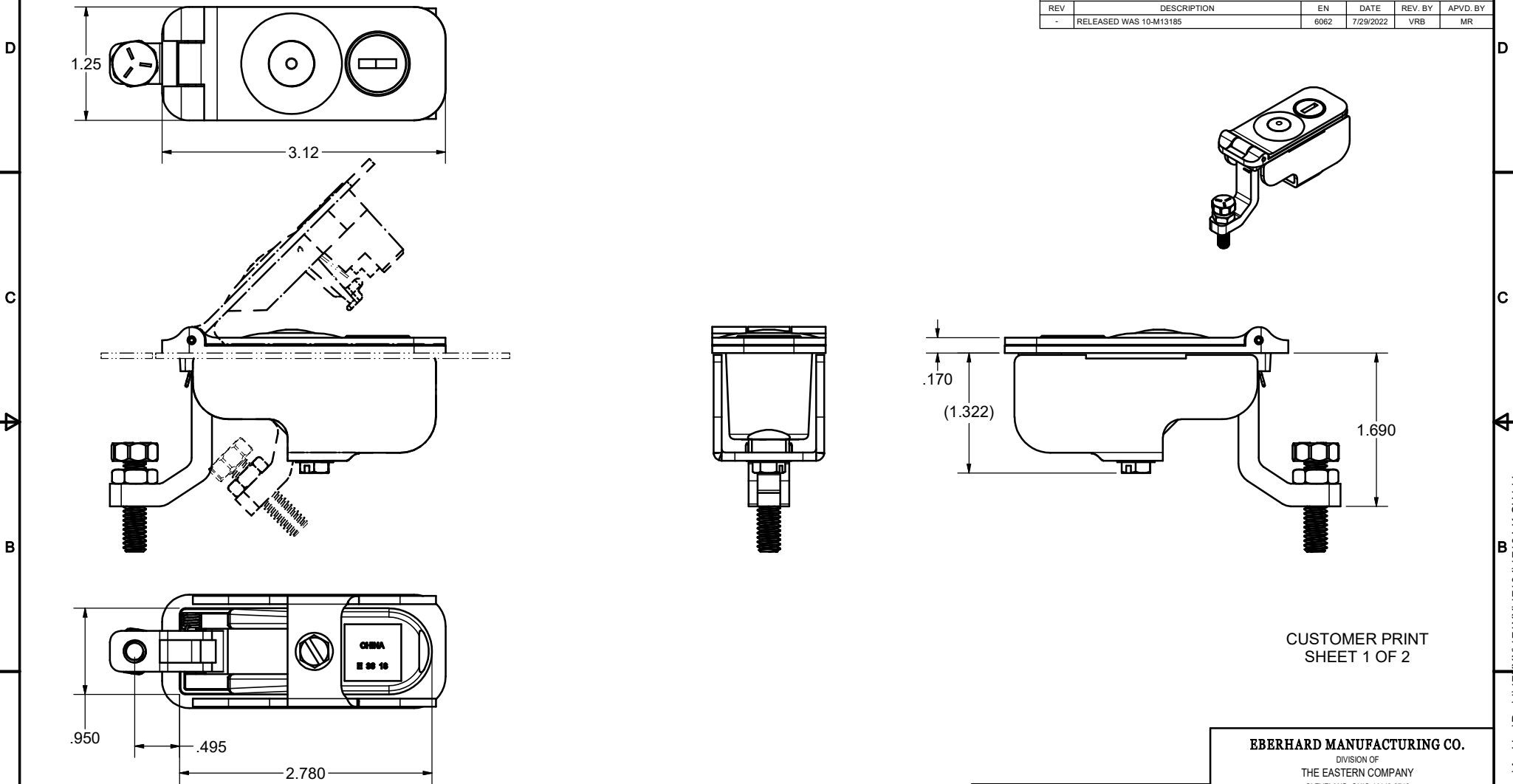

CUSTOMER PRINT  
SHEET 1 OF 2

NOTES:  
FINISHES:  
(42) BLACK POWDER, TEXTURED FOR RECEPTICLE, BUTTON AND COVER  
AVAILABLE IN KEYS 501-510, AND 545

THIS DOCUMENT IS IN ACCORDANCE WITH ASME Y14.5-2009			DATE 7/29/2022		NAME	
LINEAR MEASUREMENT: INCH			UNLESS OTHERWISE SPECIFIED TOLERANCES ARE AS FOLLOWS:		DWN. BY fbertot	
ANGLES: ± 2°			± 2°		SCALE 1:1	
2 PLACE DEC.: ± .03			± .76		MATERIAL	
3 PLACE DEC.: ± .015			± .38		PART NUMBER	
ALL HOLES: ± .005			± .13		17134-K	
			CHK. BY			
<b>EBERHARD MANUFACTURING CO.</b>						
DIVISION OF THE EASTERN COMPANY						
CLEVELAND, OHIO 44149-9712						

C:\Working\_Folder\Archive\Pro\117\XXX\171XXX\17134\17134-K SH.1.idw