

REVISION HISTORY					
REV	DESCRIPTION	EN	DATE	REV. BY	APVD. BY
0	RELEASE TO PRODUCTION: REF NPD 50079	6140	3/8/2024	KAB	MR
1	MODELS UPDATED TO CORRECT ORIENTATION FOR PAWL	6160	7/27/2024	KAB	MR
2	ADDED BREAKOUT VIEW FOR GASKET, ADDED GASKET MATERIAL TO NOTES	6161	8/2/2024	KAB	MR
3	ADDED DESCRIPTION TO PACK BARREL NUT, WASHER, KEYS, GASKET IN SEPERATE BAG, NPD50079	6167	9/13/24	KAB	MR

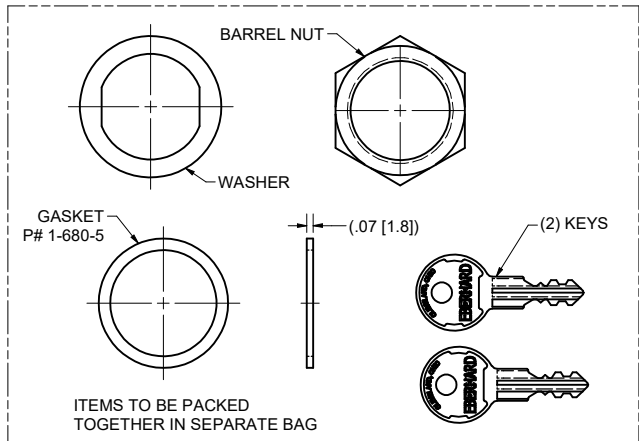
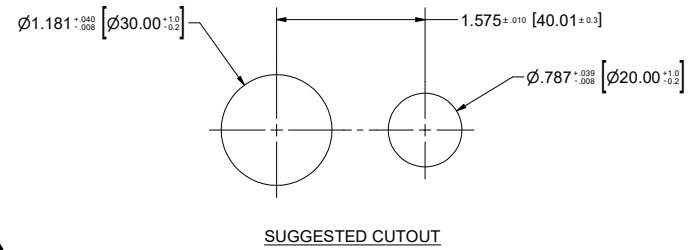
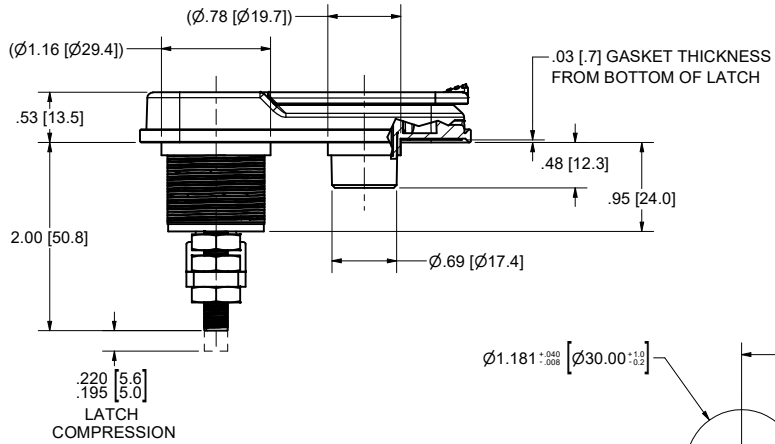
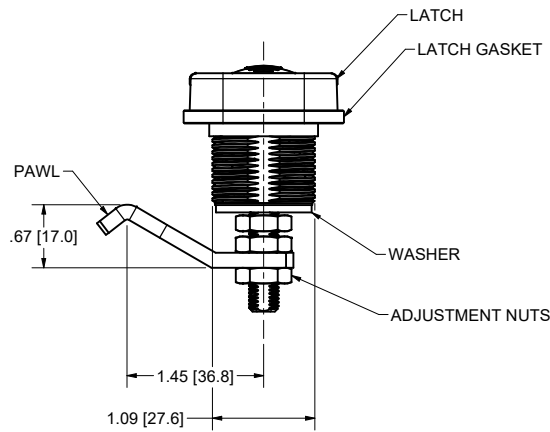
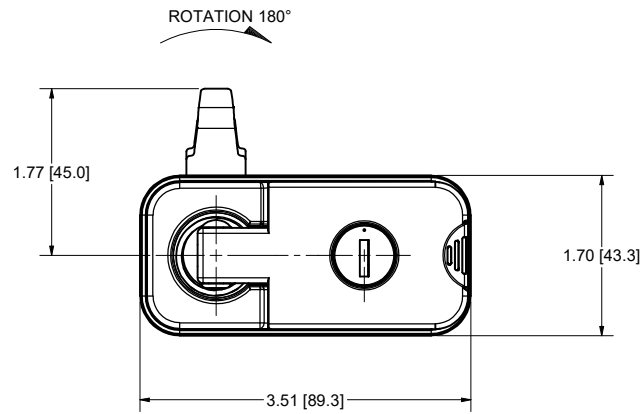
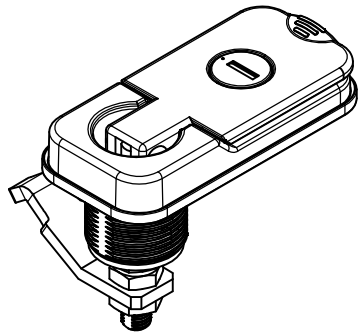

- NOTES:
 1, UNSPECIFIED TOLERANCE +/- .010
 2, MATERIAL AND PLATING MEET ROHS
 3, REFERENCE 3D MODEL FOR DETAILS.
 4, FINISH: (42) BLACK POWDER COAT (TEXTURED)
 5, TO ORDER, ORDER 1816-K-KEY#42, AVAILABLE KEY NUMBERS J201-J210
 6, GASKET MATERIAL: EPDM

THIS DOCUMENT IS IN ACCORDANCE WITH ASME Y14.5-2009		DATE: 7/26/2024		NAME:	
UNLESS OTHERWISE SPECIFIED TOLERANCES ARE AS FOLLOWS:		DWN. BY: K.Braun		SCALE: 1:1	
ANGLES:	±.2°	SCALE:	1:1	MATERIAL:	PART NUMBER
2 PLACE DEC:	±.03	±.70		SEE NOTES	1816-K
3 PLACE DEC:	±.015	±.38			
ALL HOLES:	±.005	±.18			

EBERHARD MANUFACTURING CO.
 DIVISION OF
 THE EASTERN COMPANY
 CLEVELAND, OHIO 44149-9712

LIFT & TURN LATCH LOCKING, CIRCLE MOUNT