

**CONFIDENTIAL NOTICE:** This drawing and the designs, specifications and engineering information disclosed herein are the property of Eberhard Manufacturing Company and are not to be disseminated or reproduced without express written consent. The drawing is loaned in confidence and then only for consideration of the matter disclosed herein. In accepting loan of this drawing, recipient agrees to keep it and the matter disclosed herein in confidence and not to use nor permit their use in any way detrimental to Eberhard Manufacturing Company, Division of the Eastern Company, 21944 Drake Road, Cleveland, Ohio 44149-9712 © 2012 EBERHARD MFG. CO.

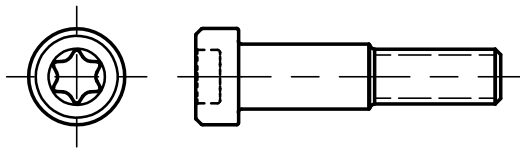

SCALE: FULL

Ø.56  
Ø.54

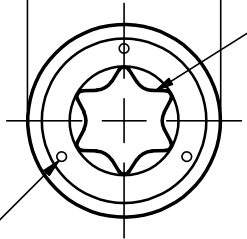

6-LOBE T45  
PENETRATION .150/.135

MANUFACTURES I.D. DOTS  
SIZE AND OPTIONAL TO  
THE MANUFACTURER.

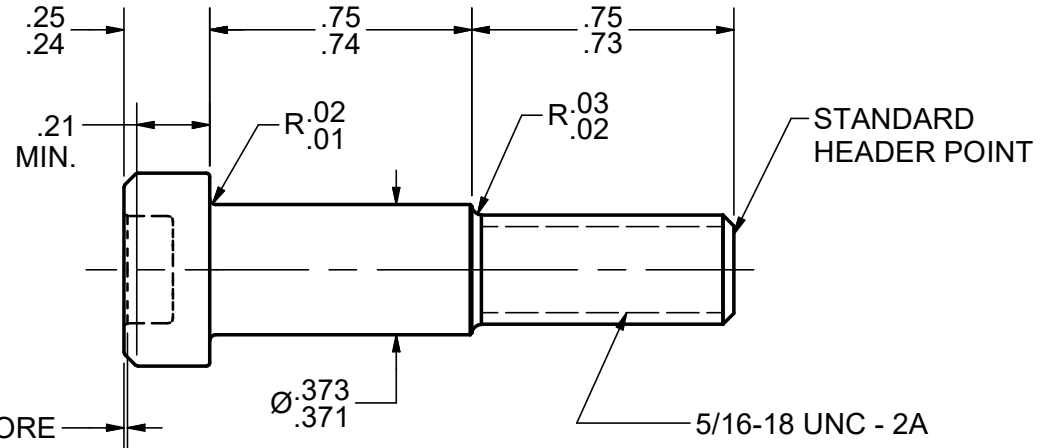

NOTES:

- 1.) MATERIAL-SAE J429, GRADE 8
- 2.) FINISH-ELECTRO ZINC (.0002) WITH  
YELLOW CHROMATE (EBERHARD'S FC 64).
- 3.) TORQUE: 22 FT.-LBS.

CUSTOMER PRINT  
SHEET 1 OF 2

SUPERSEDES DRAWING 1T-240-10 DATED 8-11-95.

1	REMOVED TORK REF: REPLACED WITH 6-LOBE PER ECR 263	5973	10/23/2020
	CONVERTED TO 3D	5542	2/24/2012
REV	DESCRIPTION	EN	DATE

LINEAR MEASURE: INCH	
UNLESS OTHERWISE SPECIFIED TOLERANCES ARE AS FOLLOWS:	
	IN MM
ANGLES:	± 2° ± 2°
2 PLACE DEC.:	± .03 ± .76
3 PLACE DEC.:	± .015 ± .38
ALL HOLES:	± .005 ± .13

DATE	2/23/2012
DR. BY	jnold
SCALE	FULL
CHK. BY	

<b>EBERHARD MANUFACTURING CO</b>
DIVISION OF <b>THE EASTERN COMPANY</b> CLEVELAND, OHIO 44149-9712
THIS DOCUMENT IS IN ACCORDANCE WITH ASME Y14.15-2009

NAME	3/8" SOCKET HEAD SHOULDER SCREW 6-LOBE W/3/4" LG. THREAD	
MATERIAL	SEE NOTE	PART NUMBER
		1T-240-10

C:\TEMP\8065a6a7-5221-495a-8096-5bc1201e7a20\FASTER\TRIKERS\1T-240-10 SH1.idw