

CONFIDENTIAL NOTICE: This drawing and the designs, specifications and engineering information disclosed hereon are the property of Eberhard Manufacturing Company and are not to be disseminated or reproduced without express written consent. The drawing is loaned in confidence and then only for consideration of the matter disclosed hereon. In accepting loan of this drawing, recipient agrees to keep it and the matter disclosed hereon in confidence and not to use nor permit their use in any way detrimental to Eberhard Manufacturing Company, Division of the Eastern Company, 21944 Drake Road, Cleveland, Ohio 44149-9712 © 2012 EBERHARD MFG. CO.

NOTES:

- 1) MATERIAL: ALLOY STEEL, GRADE 8.
- 2) FINISH: STRIKER PIN – (64) ZINC WITH YELLOW CONVERTER
WASHER – (64) ZINC WITH YELLOW CONVERTER
HEX NUT – (25) ELECTROPLATED ZINC
- 3) INSTALLATION: TORQUE TO 45/50 Ft. Lbs.

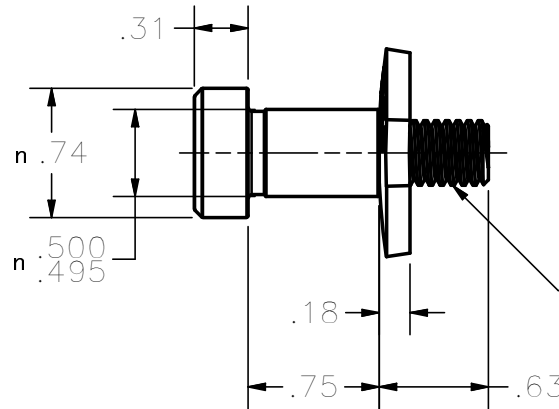
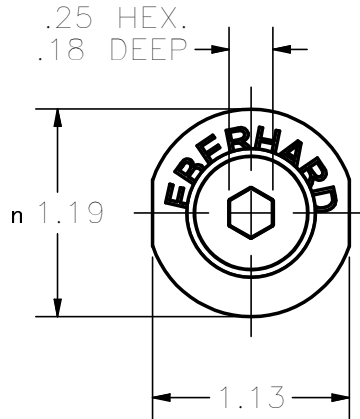

HEX FLANGE NUT
SHIPPED LLOSE
BULK PACKED

CUSTOMER PRINT
SHEET 1 OF 2

SUPERSEDES DRAWING 475-52U SHEET 1 OF 2 DATED 4-25-2002.

LINEAR MEASURE: INCH UNLESS OTHERWISE SPECIFIED TOLERANCES ARE AS FOLLOWS: ANGLES: IN MM 2 PLACE DEC.: .03 .76 3 PLACE DEC.: .015 .38 ALL HOLES: .005 .13		DATE 12/11/2012	EBERHARD MANUFACTURING CO. DIVISION OF THE EASTERN COMPANY CLEVELAND, OHIO 44149-9712	NAME STRIKER PIN, WASHER AND HEX NUT SUB-ASSEMBLY
REVISED AND REDRAWN, CONVERTED TO 3D		EN 5583	12/14/2012	MATERIAL -----
REV	DESCRIPTION	EN	DATE	PART NUMBER 475-52U

C:\Working_Folder\Archive\FASSTENER\STRIKERS\475-52U\SH1.idw