

CONFIDENTIAL NOTICE: This drawing and the designs, specifications and engineering information disclosed herein are the property of Eberhard Manufacturing Company and are not to be disseminated or reproduced without express written consent. The drawing is loaned in confidence and then only for consideration of the matter disclosed herein. In accepting loan of this drawing, recipient agrees to keep it and the matter disclosed herein in confidence and not to use nor permit their use in any way detrimental to Eberhard Manufacturing Company, Division of the Eastern Company, 21944 Drake Road, Cleveland, Ohio 44149-9712 © 2012 EBERHARD MFG. CO.

REVISION HISTORY					
REV	DESCRIPTION	EN	DATE	REV.BY	APVD.BY
1	RELEASED PER NPD 50132	6142	3/22/2024	DJK	MR

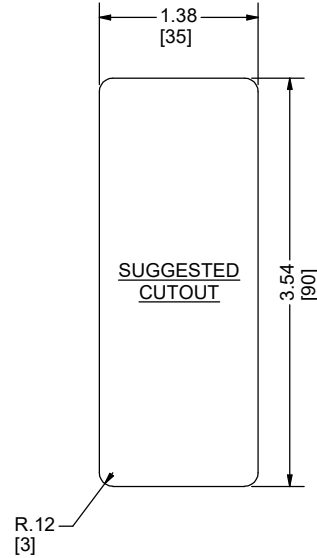
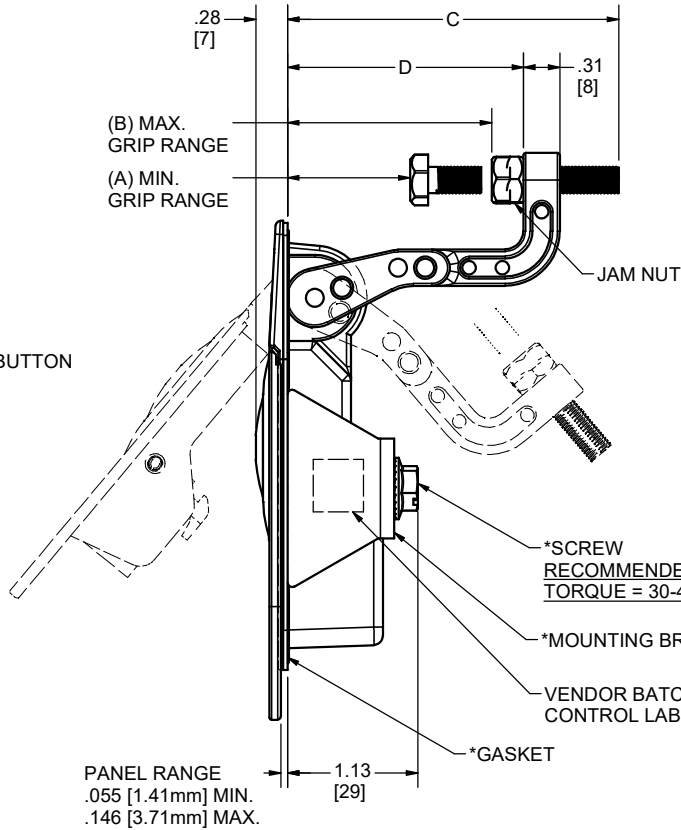
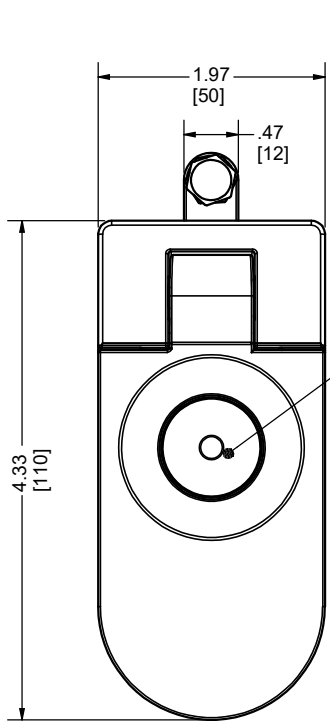

- NOTES:**
1. EBERHARD AVAILABLE FINISH:
(42) BLACK POWDER (TEXTURED)
 2. *GASKET, MOUNTING BRACKET, AND SCREW SHIPPED LOOSE IN A SECURED POLY BAG, PLACED IN A LARGER BAG WITH TRIGGER LATCH.

PART NUMBER CHART, in. [mm]				
PART NO.	A	B	C	D
834RW	0 [0]	.55 [14]	1.58 [40]	.79 [20]
835RW	.35 [9]	1.14 [29]	2.21 [56]	1.42 [36]
836RW	.98 [25]	1.77 [45]	2.84 [72]	2.05 [52]
837RW	1.45 [37]	2.24 [57]	3.27 [83]	2.48 [63]

THIS DOCUMENT IS IN ACCORDANCE WITH ASME Y14.15-2009	
LINEAR MEASURE: INCH	DATE: 3/22/2024
UNLESS OTHERWISE SPECIFIED TOLERANCES ARE AS FOLLOWS:	DR.BY: DJK
ANGLES: ± 2° ± 2°	SCALE: *
2 PLACE DEC.: ± .03 ± .76	CHK.BY:
3 PLACE DEC.: ± .015 ± .38	
ALL HOLES: ± .005 ± .13	

CUSTOMER PRINT

EBERHARD MANUFACTURING CO.
DIVISION OF
THE EASTERN COMPANY
CLEVELAND, OHIO 44149-9712

NAME: TRIGGER LATCH (NON-LOCKING)	
MATERIAL:	PART NUMBER: 834RW
CHART:	

C:\Working_Folder\Archive\Pro\834RW SH1.idw