

CONFIDENTIAL NOTICE: This drawing and the designs, specifications, and engineering information hereon are the property of Eberhard Manufacturing Company and are not to be disseminated or reproduced without express written consent. This drawing is loaned in confidence and then only for the consideration of the matter disclosed hereon. In accepting loan of this drawing, recipient agrees to keep it and the matter disclosed hereon in confidence and not to use or permit their use in any way detrimental to Eberhard Manufacturing Company, Division of The Eastern Company, 21944 Drake Road, Cleveland, Ohio, 44149-9712 © 2023 EBERHARD MFG. CO.

REVISION HISTORY					
REV	DESCRIPTION	EN	DATE	REV. BY	APVD BY
0	REVISED AND REDRAWN, CHGD FROM ILC BORDER, PER CPP4312.	6128	12/8/2023	KAB	MR
1	ADDED EMC SUPPORT CARD AND SILICA GEL PACK TO BAG	6148	05/03/2024	MAM	MR

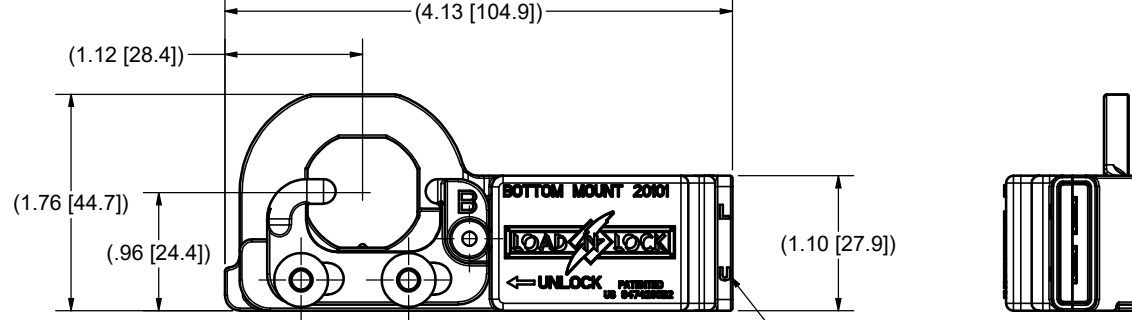
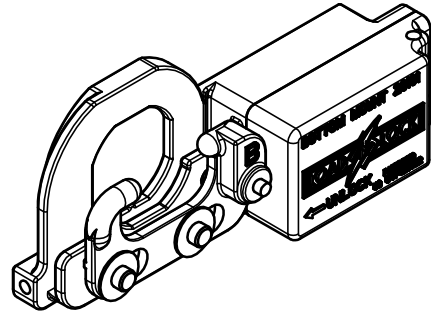

POLARITY NEEDS TO BE WHEN (+) DVC IS APPLIED TO 90U TERMINAL THE SOLENOID IS RETRACTED AS SHOWN.

RETAINING E-CLIP (00584), SILICA GEL PACK, AND EMC SUPPORT CARD (EMC-SUPRTCARD-001) TO BE INCLUDED IN POLY BAG WITH POWER LOCK ASSEMBLY. ①

NOTE: INSTALL 00667 WASHER THEN WELD, MAINTAIN MIN. 0.010" CLEARANCE BETWEEN PARTS 00637 AND 00644 FOR SMOOTH MOVEMENT

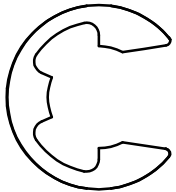

00667 WASHERS TO BE SONIC WELDED ONTO 00644 FRAME

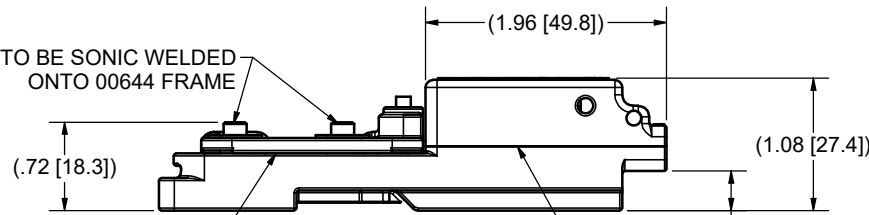

APPLY LIGHT GREASE BETWEEN PARTS 00644 AND 00637

SONIC WELD PART 00644 TO PART 21101 AROUND ENTIRE PERIMETER. MUST BE FLUSH.

PARTS LIST

ITEM	QTY	PART NUMBER	DESCRIPTION
1	1	00644	SOLENOID FRAME, BOTTOM MOUNT
2	1	20201	SOLENOID, LOCK .180" TRAVEL AT 2 LBS
3	1	00637	SLIDER PLATE BOTTOM MOUNT
4	2	00642	SOLENOID WIRE TERMINAL. 90 DEG. .25" MALE SPADE, SOLDER ON.
5	1	21101	SOLINOID COVER BOTTOM MOUNT
6	1	00584	E-CLIP EXTERNAL
7	2	00667	WASHER, SS .188"OD, .440"OD
8	1	EMC-SUPRTCARD-001	EMC SUPPORT CARD ①

THIS DOCUMENT IS IN ACCORDANCE WITH ASME Y14.5-2009		
LINEAR MEASUREMENT - INCH	DATE	
UNLESS OTHERWISE SPECIFIED TOLERANCES ARE AS FOLLOWS:	12/1/2023	
ANGLES:	± 2°	± 2°
2 PLACE DEC.:	± .03	± .76
3 PLACE DEC.:	± .015	± .38
ALL HOLES:	± .005	± .13

EBERHARD MANUFACTURING CO. DIVISION OF THE EASTERN COMPANY CLEVELAND, OHIO 44149-9712	
NAME	ES POWER MODULE, BOTTOM MOUNT, 13VDC
DATE	12/1/2023
DWN. BY	jhole
SCALE	1:1
CHK. BY	
MATERIAL	PART NUMBER
	LNL-72-20101