

| REVISION HISTORY |  |      |            |         |          |
|------------------|--|------|------------|---------|----------|
| REV              | DESCRIPTION                            | EN   | DATE       | REV. BY | APVD. BY |
| -                | RELEASED PER NPD 50087 REV 2           | 6155 | 6/21/2024  | DJK     | MR       |
| 1                | MODIFIED VIEW & ADDED MTG HOLE PATTERN | 6171 | 10/11/2024 | DJK     | MR       |

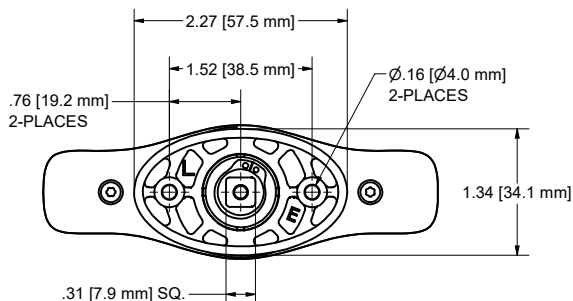
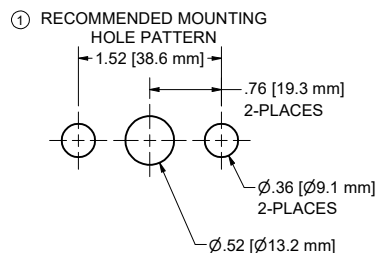
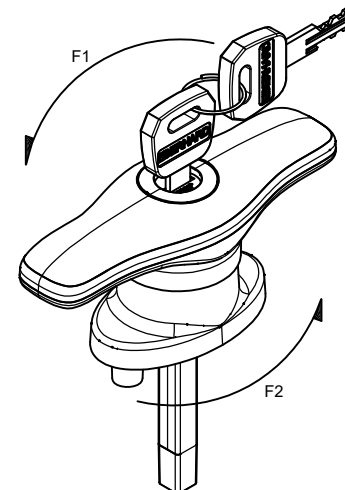
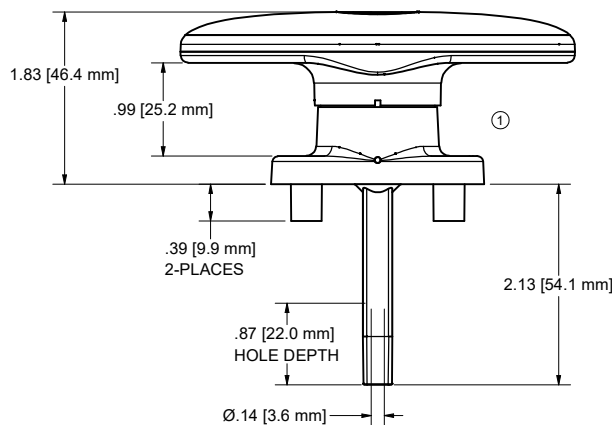
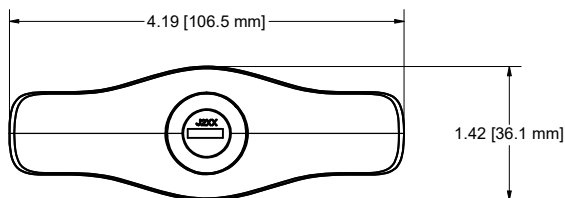
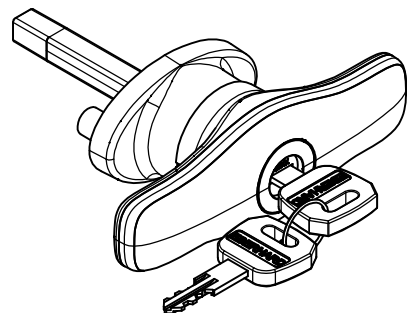

FINISH CODE  
KEY NUMBER

**ORDER NOTES:**

- TO ORDER, PA501-CCW-J2XX-MB
- KEY NUMBERS AVAILABLE:  
J201-J210, J236
- TWO KEYS SUPPLIED
- EBERHARD AVAILABLE FINISH:  
(MB) MATTE BLACK

**NOTES:**

- LOCKED 12 O'CLOCK POSITION SHOWN. UNLOCKED AT 3 O'CLOCK POSITION.
- FILLED PLUG AND KEY CODES REFERENCE KEY CUTTING & COMBINATION DRAWING.
- HANDLE 90 DEGREE CCW ROTATION ONLY IN UNLOCK POSITION.
- MATERIAL AND FINISH TO COMPLY WITH (EU) ROHS DIRECTIVE.
- PACKAGING REFERENCE DRAWING.
- ASSEMBLY PART COMPLY WITH THE FOLLOWING TESTS:

- 300Hrs SALT APRAY ACC TO ASTM B117
- 300Hrs UV ACC TO ASTM G 154-16 1 CYCLE
- STATIC TESTING REQUIREMENTS:  
TEMPERATURE RANGE FORM +80°C TO -30°C HUMIDITY(65%RH) DURATION (12H EACH)  
F1 )HANDLE MUST WITHSTAND A 25 lbf-Eft TORQUE FORCE  
F2 )HANDLE BASE MUST WITHSTAND A 40 lbf-Eft TORQUE FORCE

CUSTOMER PRINT

**EBERHARD MANUFACTURING CO.**  
DIVISION OF  
THE EASTERN COMPANY  
CLEVELAND, OHIO 44149-9712

LOCKING T-HANDLE CCW

PART NUMBER  
**PA501-CCW**

|   |           |         |     |
|---|-----------|---------|-----|
| THIS DOCUMENT IS IN ACCORDANCE WITH ASME Y14.5-2009 |           |         |     |
| LINEAR MEASUREMENT: INCH [MM]                       | DATE      | NAME    |     |
| UNLESS OTHERWISE SPECIFIED                          | 6/21/2024 |         |     |
| TOLERANCES ARE AS FOLLOWS:                          | DWN. BY   |         |     |
|   | dkoegele  |         |     |
| ANGLES:   | ± 2°      | SCALE   | 1:1 |
| 2 PLACE DEC.:                                       | ± .03     | ± .70   |     |
| 3 PLACE DEC.:                                       | ± .015    | ± .38   |     |
| ALL HOLES:  | ± .005    | ± .15   |     |
|   |           | CHR. BY |     |