



Standard Wing Locks

DC690, 695 Series

- Outdoor wing locks resist moisture, dust, salt and extreme temperatures
- Various Cams, rotations and key pulls
- Available keyed-alike or keyed-different in multiple lengths
- 200 key changes
- Automotive style dust shutter
- Automotive style reversible key with optional plastic over molding
- DC690 Series can be used with rotary / slam latches

Material and Finish

Housing: Zinc Alloy with stainless steel scalp and upgraded dust shutter

Finish: Textured black powder coat

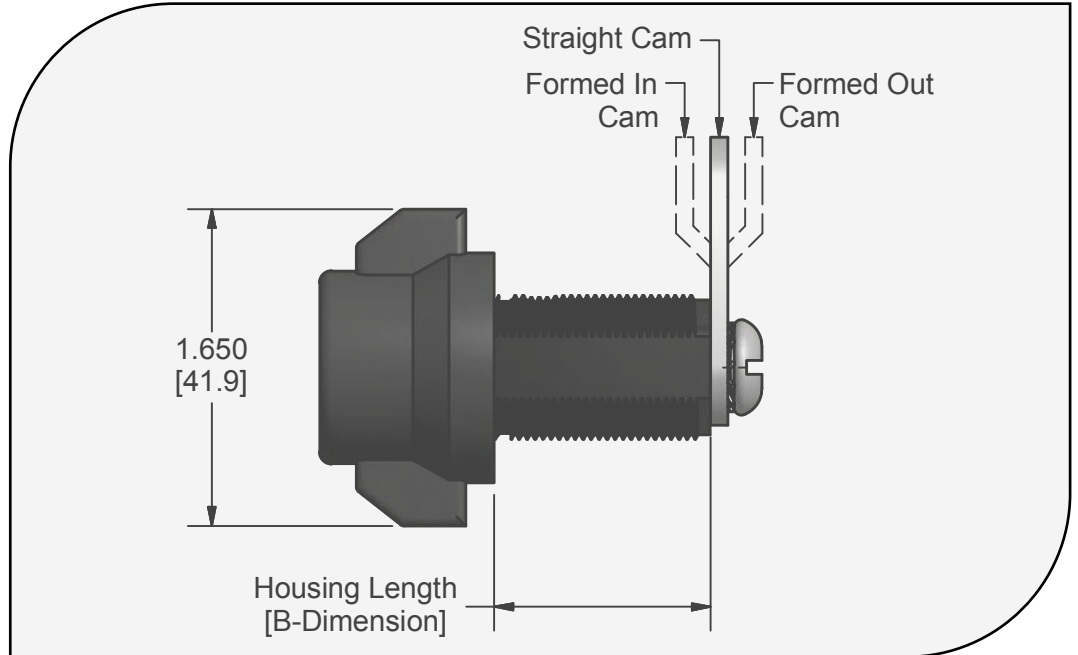

Part No.	Housing Length [B-Dim]		Spring Returning
	Inches	Millimeters	
DC690S	5/8	33.8	Yes
DC695S	5/8	33.8	No
DC690M	7/8	33.8	Yes
DC695M	7/8	33.8	No
DC690L	1 1/8	33.8	Yes
DC695L	1 1/8	33.8	No
DC690XXL	1 5/8	33.8	Yes
DC695XXL	1 5/8	33.8	No
DC690XXXXL	2 1/8	33.8	Yes
DC695XXXXL	2 1/8	33.8	No



Illinois Lock Company

A division of the Eastern Company

www.illinoislock.com • sales@illinoislock.com • 847-537-1800



Standard Wing Locks

DC690, 695 Series

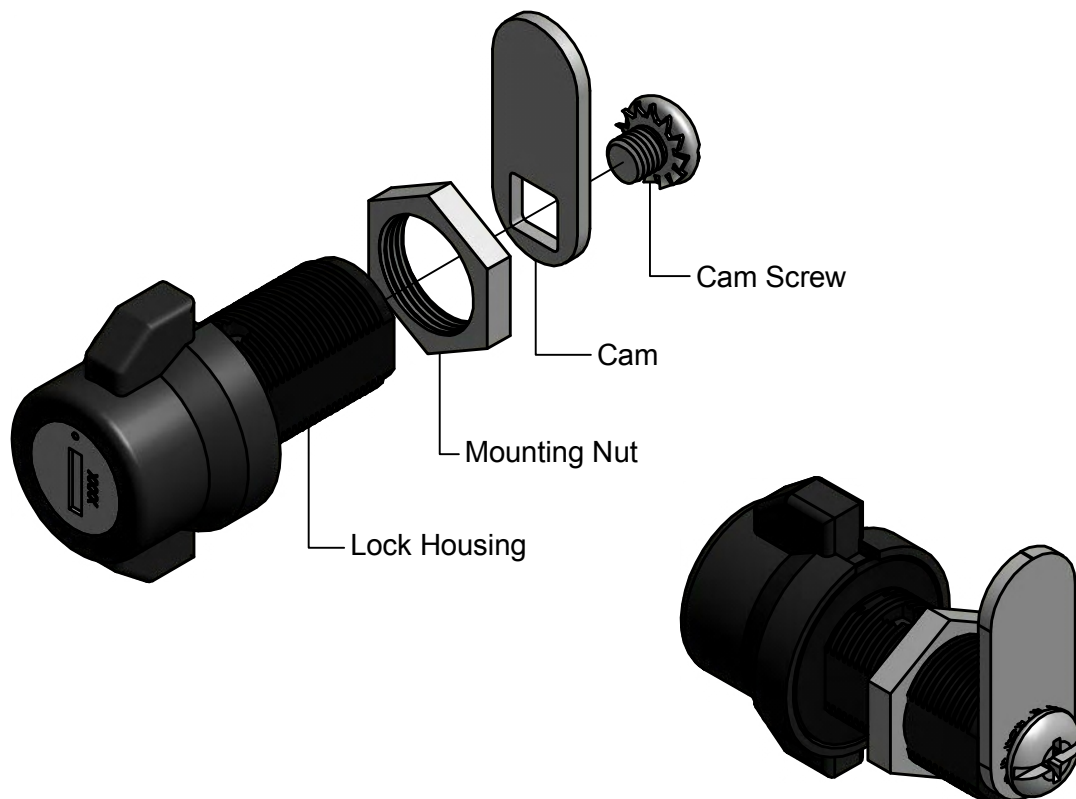

Cam Rotation and Installation

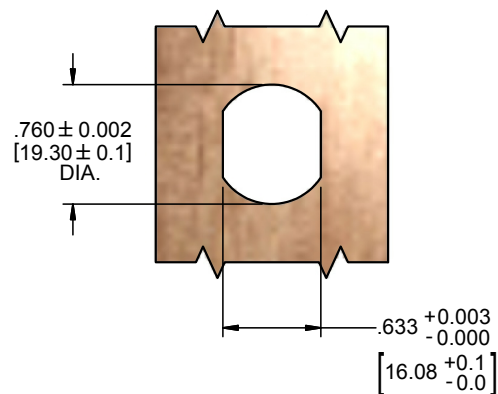
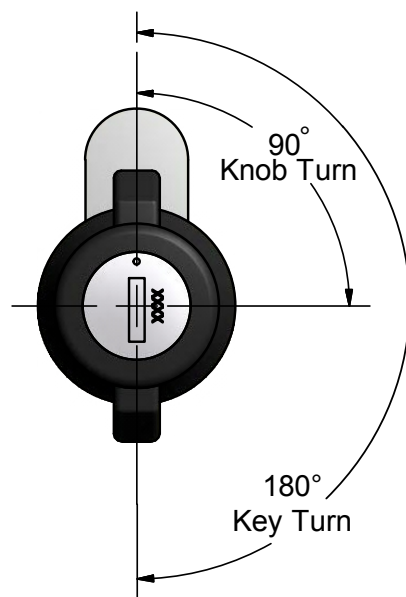



Standard Wing Locks

DC690, 695 Series

Cam Types

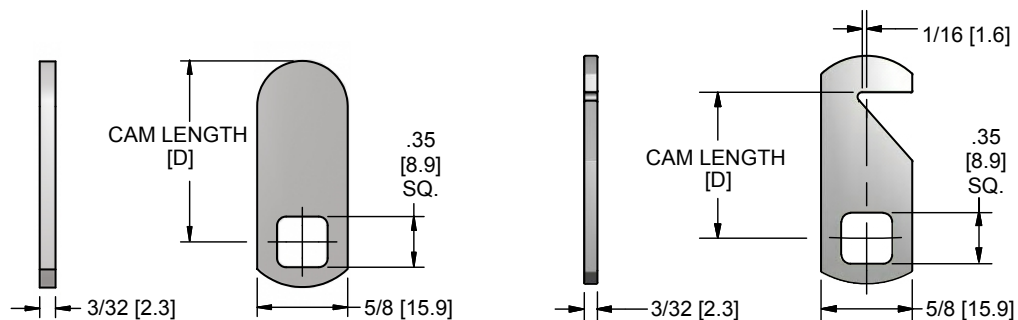

Straight Cams		
Part Number	Cam Length [D-Dim]*	
	Inches	Millimeters
TS2201-13	7/8	22.2
TS2201-17	1	25.4
TS2201-19	1-1/8	28.6
TS2201-21	1-1/4	31.7
TS2201-23	1-3/8	34.9
TS2201-25	1-1/2	38.1
TS2201-27	1-5/8	41.3
TS2201-29	1-3/4	44.4
TS2201-31	1-7/8	47.6
TS2201-33	2	50.8

Hook Cams		
Part Number	Cam Length [D-Dim]*	
	Inches	Millimeters
TS2204-13	7/8	22.2
TS2204-17	1	25.4
TS2204-19	1-1/8	28.6
TS2204-21	1-1/4	31.7
TS2204-23	1-3/8	34.9
TS2204-25	1-1/2	38.1
TS2204-27	1-5/8	41.3
TS2204-29	1-3/4	44.4
TS2204-31	1-7/8	47.6
TS2204-33	2	50.8

* length tolerance +/- .039" [1mm]



Standard Wing Locks

DC690, 695 Series

Cam Types - Continued

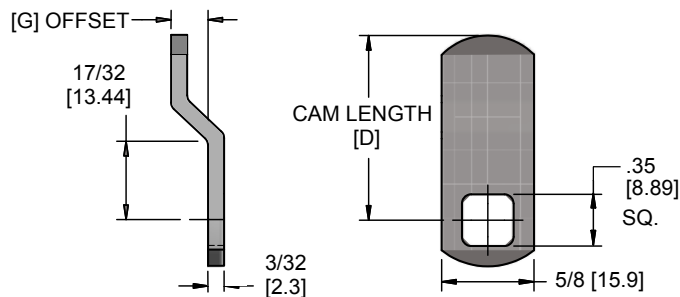

Offset Cams				
Part Number	Cam Length [D-Dim]*		Offset Length [G-Dim]*	
	Inches	Millimeters	Inches	Millimeters
TF2201-13-02	7/8	22.2	1/16	1.6
TF2201-13-04	7/8	22.2	1/8	3.2
TF2201-13-06	7/8	22.2	3/16	4.8
TF2201-15-08	15/16	23.8	1/4	6.4
TF2201-17-02	1	25.4	1/16	1.6
TF2201-17-04	1	25.4	1/8	3.2
TF2201-17-06	1	25.4	3/16	4.8
TF2201-19-08	1-1/8	28.6	1/4	6.4
TF2201-21-04	1-1/4	31.7	1/8	3.2
TF2201-21-06	1-1/4	31.7	3/16	4.8
TF2201-21-08	1-1/4	31.7	1/4	6.4
TF2201-25-04	1-1/2	38.1	1/8	3.2
TF2201-25-06	1-1/2	38.1	3/16	4.8
TF2201-25-08	1-1/2	38.1	1/4	6.4
TF2201-29-04	1-3/4	44.4	1/8	3.2
TF2201-29-06	1-3/4	44.4	3/16	4.8
TF2201-29-08	1-3/4	44.4	1/4	6.4
TF2201-33-02	2	50.8	1/16	1.6
TF2201-33-04	2	50.8	1/8	3.2
TF2201-33-06	2	50.8	3/16	4.8
TF2201-33-08	2	50.8	1/4	6.4



Standard Wing Locks

DC690, 695 Series

Accessories/Replacement Parts



Cam Screw 1/4-28
PN: S23032G

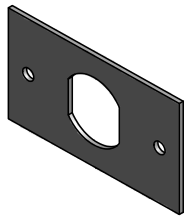

Anchor Plate
PN: S2315A



Nut Lock
PN: S9003A



Barrel Nut M19
PN: D9868



Spur Washer
PN: S2302A



Spur Washer
PN: S2302B



Anchor Washer
PN: S6951



Flat Washer
PN: S2313



Speed-Clip
PN: HS6397